

A-A (1:1)

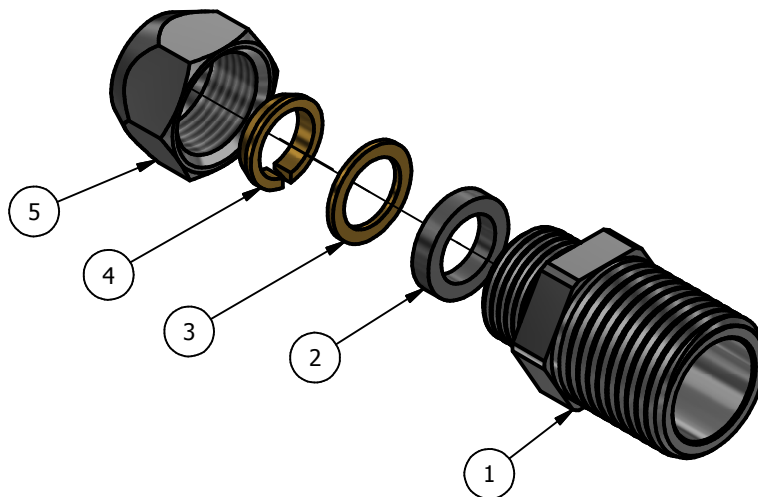
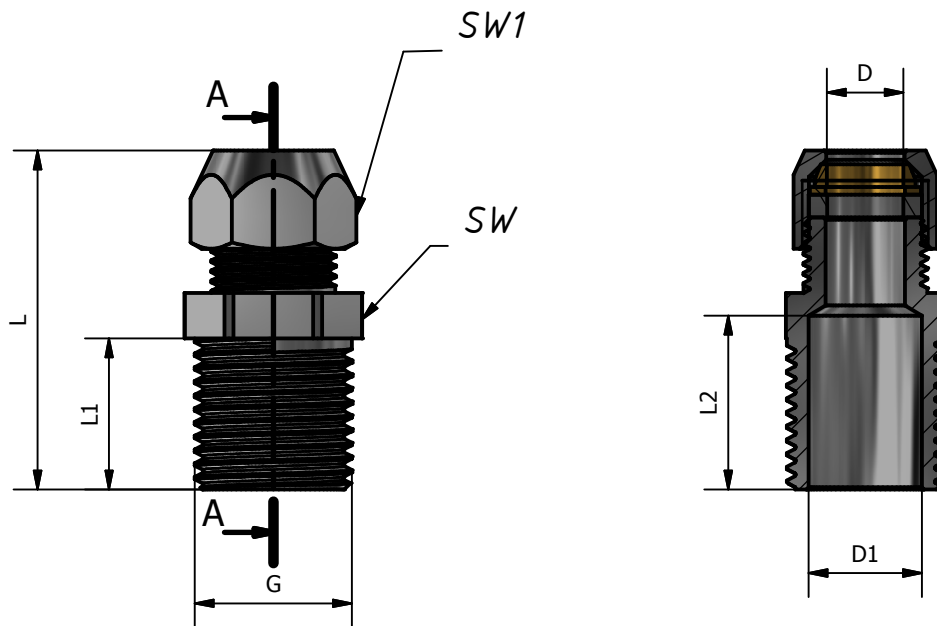

CODE	SIZE	G	D	D1	L	L1	L2	SW	SW 1
373 3810	3/8x10	3/8	10	12	45	20	23	17	19
373 3812	3/8x12	3/8	12	12,5	45	20	23	17	19
373 1210	1/2x10	1/2	10	15	45	20	23	21	19
373 1212	1/2x12	1/2	12	15	45	20	23	21	19
373 1214	1/2x14	1/2	14	15	47	20	23	21	23

N°	DESCRIPTION	MATERIAL
1	BODY	CW 617N EN 12165
2	FLAT RUBBER	NBR 70
3	FLAT WASHER	CW617N EN12164
4	CUTTING RING	CW617N EN12164
5	NUT	CW617N EN12165

CONFORMITY
1) DM 174 del 6 Aprile 2004
2) UNI EN ISO 228
3) UNI EN 1254-2
4) UNI EN681-1
5) UNI EN 9227
6) UNI EN 2819

WORKING PRESSURE MAX	10 BAR
WORKING TEMPERATURE MIN- MAX	0°C 80°C

00	Prima emissione	Delaini M.	14/02/2012
Rev.	Nota Revisione	Approvatore	Data Approvazione

Toll Gen: JS13	Stato sup.: Cromato
Filetto: ISO 228	Note tecniche:
Peso lavorato:	Peso grezzo:
	N° stampo:

Codice: 373 scheda

Descrizione: Raccordo dritto maschio per tubo rame

Materiale:

Disegnatore:
Delaini P.

Data: 13/02/2012

TDM Brass s.r.l via Artigiani, 7-9 25030 Maclodio BS Italy tel +39 030 9972217 fax 030 9787089 www.tdmbrass.it email info@tdmbrass.it

TDM BRASS
Italian Fittings